

Preservation

above-zero

Blood Bank Refrigerators

Specially designed to provide precise and reliable temperature control that meets various criteria for whole blood and blood derivatives.



MBR-705GR

The Panasonic MBR Series provides two styles of storage systems: G-type (coated hard steel wire shelf) and GR-type (stainless steel roll-out drawers with card holder).

Designed to conform to AABB criteria, the series ensures stable and reliable temperature control utilizing Panasonic original technology. A special highly efficient compressor designed and developed by Panasonic provides rapid cooling and quiet performance for each model.

Temperature Variations Prevented

The Panasonic MBR Series is designed to minimize cold air loss even with frequent door openings.

- **Separated transparent inner doors** minimize the chamber air leakage during door openings.
- **Foamed-in-place insulation** in the walls and **magnetic sealed outer doors with double-pane glass window** prevent chamber air leakage and promote complete door closings.
- **Large air circulation fan** enables rapid temperature recovery after door openings.

Alarm and Safety Functions

To ensure the safety of precious blood supply, the Panasonic MBR Series provides the following safety functions:

- **Audible and flashing LED visual alarms** with remote alarm contacts, in case of power failure, high or low temperature condition, or any thermal sensor abnormality.
- Door alarm and key lock are standard features.
- Re-activating buzzer, lamp and remote alarm contact. (30 min. after buzzer stops)
- Built-in temperature recorder.

Stable Temperature Control

- Temperature is controlled by two sensors located in the liquid-loaded **monitor bottles**, which are in the shape of a blood bag.
- **Two thermistor sensors** constantly monitor the temperature in both the upper and the lower part of chamber.
- **Microprocessor control** ensures the most accurate temperature control available.
- **Multi air-flow plenum system** ensures excellent temperature uniformity in larger capacity

Specifications

Model No.	MBR-705GR
Exterior dimensions (W x D x H)	770 x 830 x 1955 (mm) / 30.3 x 32.7 x 77.0 (inch)
Interior dimensions (W x D x H)	650 x 697 x 1500 (mm) / 25.6 x 27.4 x 59.1 (inch)
Net weight	213 kg (470 lbs.)
Effective capacity	622 liters [22.0 cu.ft.]
Storage capacity	360 bags (450mL), without baskets
Exterior cabinet	Galvanised steel with baked-on finish
Interior cabinet	Galvanised steel with baked-on finish
Cabinet insulation	Foamed-in-place rigid polyurethane
Outer door	Insulated steel frame with double-layer glass windows
Door lock	1
Inner door (acrylic)	3
Shelves	—
Drawers	6 stainless steel roll-out drawers
Casters	4
Compressor	220W hermetically sealed
Refrigerant	HFC
Temperature	4°C ±1°C (Ambient temperature 35°C)
Air circulation	Forced air circulation
Defrost	Fully automatic
Temperature control	Microprocessor control
Temperature alarm	High (6°C), Low (2°C), Audible and visual alarm
Power failure alarm	Audible and visual alarm (24 hours), Automatic rechargeable battery (Ni-MH)
Door alarm	Audible and visual alarm
Part replacement notification	Fan motor, Battery
Remote alarm contact	DC30V, 2A, Temperature alarm or power failure alarm
Temperature monitor	2 bottles with thermistor sensor
Lighting	20W fluorescent lamp
Access port	2
Accessories	1/7/30-day circular recorder, Door lock key
Options	Recording paper (RP-G04-PW), Recording pen (PG-R-PW)
	Data acquisition system (MTR-5000-PW/MTR-L03-PW or MTR-480-PW)

User-Friendly Design

- **Selectable storage system** (G-type and GR-type) to suit user's needs.
- **Fluorescent interior lamp** with ON/OFF switch and a **large view window** in the outer door provide a clear view of stored items.
- **Digital display** is easy to see, and is calibratable through the control panel.



Easy-access front control panel (MBR-305GR)

- Filterless construction eliminates bothersome filter cleaning.

Performance Data (Reference Data)

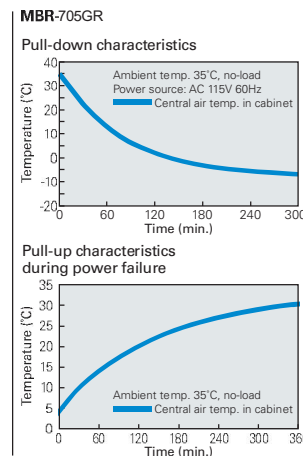

* A continuously operating compressor was used to obtain data for the upper three graphs.

Dimensions Unit: mm (inch)

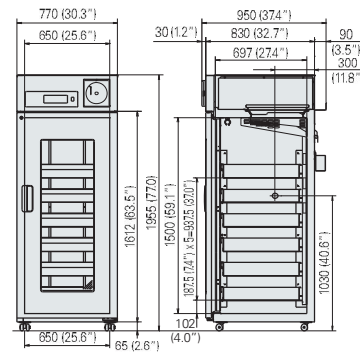

MBR-705GR



Panasonic Healthcare Co., Ltd., Gunma Factory is certified for:
Quality management system: ISO9001
Medical devices quality management system: ISO13485



Panasonic Healthcare Co., Ltd., Gunma Factory is certified for:
Environmental management system: ISO14001

DISTRIBUTED BY:



PT. SIGMA BIMED

Indonesia Sole Distributor

Jl. Agung Utara Raya Blok A 36D/42 Sunter Agung Jakarta Utara 14350 Indonesia

Telp. (62-21) 64716568, 70240088, 70240099, 87960123, 87960456

Fax. (62-21) 64716566, 87961123, 87961456

Email : sigmabimed@indo.net.id, sales@sigmabimed.com

Website : www.sigmabimed.com

Panasonic

<http://panasonic.net/healthcare/biomedical/>